

11 to rear frame short

(300 mm short wheelbase)

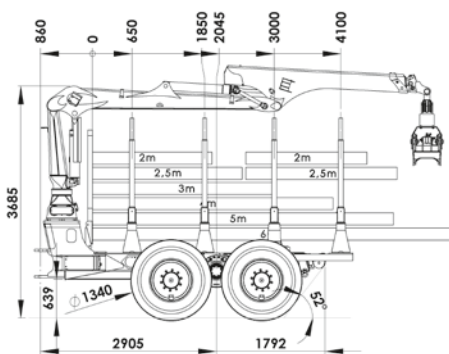

11 to rear frame with tilt-crane

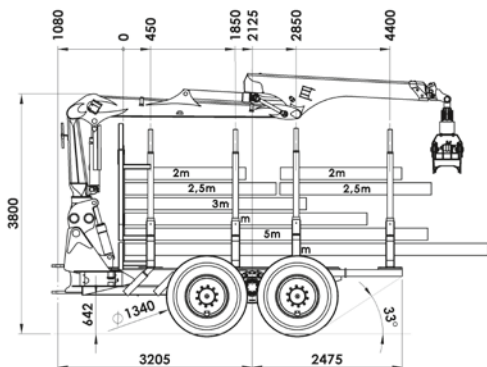

12 to rear frame with tilt-crane

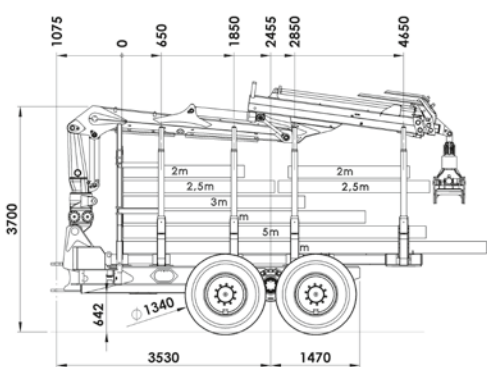

14 to rear frame with tilt-crane

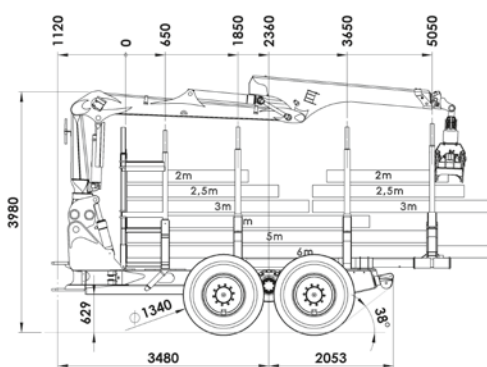

Diagrammed:

- 4th rung pluggable
- single drum-rearwinch
- 3rd rung turnable

Diagrammed:

- crane tiltable with angle - 5° / + 26°
- grid displaceable and demountable
- quick-change plate
- 4th rung pluggable

Diagrammed:

- crane tiltable with angle - 5° / + 26°
- grid hydraulic moveable
- rungs relocatable
- turnable last rung

Diagrammed:

- crane tiltable with angle - 5° / + 26°
- grid displaceable and demountable
- single drum-rearwinch 10 to
- rungs relocatable
- 4th rung pluggable

Special equipment:

- grid, high adjustable
- rungs telescopic (width)
- clambunk with quick-change system
- moveable rungs
- single drum-rearwinch
- turnable rung
- grid pluggable
- 4th rung pluggable
- other options on request

HSM Crane-list

		X = available against surcharge			O = standard equipment			# = not available	
Crane typ	lift moment	reach	grapple Typ	208F	208F	208F	208F	208F14to	
				11 to	12 to	14 to	Kombi	Steilhang	
Messera Loglift	F59 F72	78/56 kNm	7,2 m	FG43S	#	#	#	#	#
	F59 FT85	78/51 kNm	8,5 m	FG43S	#	#	#	#	#
	F59 FT100	78/47 kNm	10,0 m	FG43S	#	#	#	#	#
	F59 FT100i	78/47 kNm	10,0 m	FG43S	#	#	#	#	#
	F71 F72	99/75 kNm	7,2 m	FG43S	X	X	X	X	#
	F71 FT85	99/70 kNm	8,5 m	FG43S	X	X	X	X	#
	F71 FT100	99/66 kNm	10,0 m	FG43S	X	X	X	X	#
	F71 FT100i	99/66 kNm	10,0 m	FG43S	X	X	X	X	#
	F83 F72	106/82 kNm	7,2 m	FG43S	X	X	X	X	#
	F83 FT85	106/76 kNm	8,5 m	FG43S	X	X	X	X	#
	F83 FT100i	106/73 kNm	10,0 m	FG43S	X	X	X	X	#
	M 92 F80i	130/84 kNm	8,0 m	FG43S	X	X	X	X	X
	M 92 FT86i	130/84 kNm	8,6 m	FG43S	X	X	X	X	X
	M 92 FT100i	130/84 kNm	10,0 m	FG43S	X	X	X	X	X
	F111 F72	151/111 kNm	7,2 m	FG43S	#	X	X	X	#
	F111 F85	151/100 kNm	8,5 m	FG43S	#	X	X	X	#
	F111 FT85	151/100 kNm	8,5 m	FG43S	#	X	X	X	#
	F111 FT91	151/98 kNm	9,1 m	FG43S	#	X	X	X	#
	F111 FT100	151/101 kNm	10,0 m	FG43S	#	X	X	X	#
	M122 F85i	155/110 kNm	8,5 m	FG43S	#	X	X	X	#
	M122 F96i	155/ - kNm	9,6 m	FG43S	#	X	X	X	#
	M122 FT100i	155/ - kNm	10,0 m	FG43S	#	X	X	X	#
	M142 F85i	178/132 kNm	8,5 m	FG43S	#	X	X	X	#
	M142 F96i	178/124 kNm	9,6 m	FG43S	#	X	X	X	#
	M142 FT100i	178/ - kNm	10,0 m	FG43S	#	X	X	X	#
Epsilon	C60 F69	82/63 kNm	6,9 m	FG43S	#	#	#	#	#
	C60 F86	82/51 kNm	8,6 m	FG43S	#	#	#	#	#
	M70 F80	102/68 kNm	8,0 m	FG43S	O	O	O	O	#
	M70 F86	102/68 kNm	8,6 m	FG43S	X	X	X	X	#
	M70 F101	102/65 kNm	10,1 m	FG43S	X	X	X	X	#
	M80 F80	114/79 kNm	8,0 m	FG43S	X	X	X	X	#
	M80 F86	114/79 kNm	8,6 m	FG43S	X	X	X	X	#
	M80 F101	114/75 kNm	10,1 m	FG43S	X	X	X	X	#
	S100 F80	128/91 kNm	8,0 m	FG43S	X	X	X	X	O
	S100 F86	128/90 kNm	8,6 m	FG43S	X	X	X	X	X
	S100 F101	128/86 kNm	10,1 m	FG43S	X	X	X	X	X
	S110 F80	143/104 kNm	8,0 m	FG43S	X	X	X	X	X
	S110 F86	143/104 kNm	8,6 m	FG43S	X	X	X	X	X
	S110 F101	143/100 kNm	10,1 m	FG43S	X	X	X	X	X
	X120 F80	159/111 kNm	8,0 m	FG43S	#	X	X	X	#
	X120 F86	159/110 kNm	8,6 m	FG43S	#	X	X	X	#
	X120 F102	159/107 kNm	10,2 m	FG43S	#	X	X	X	#
	X140 F80	173/123 kNm	8,0 m	FG43S	#	#	X	X	#
	X140 F86	173/122 kNm	8,6 m	FG43S	#	#	X	X	#
	X140 F102	173/119 kNm	10,2 m	FG43S	#	#	X	X	#
	low crane column (height 1730 mm) series at steep slope and kombi				X	X	X	O	O

Technical subject to change. July 2014 HSM208F-6Z_en_photon-sh-0714



HSM 208F 6 Cylinder Model



HSM Hohenloher Spezial-Maschinenbau GmbH & Co. KG

Technik die Freude macht.

D-74635 Neu-Kupfer
Im Greut 10
Tel. + 49 (0) 7944 / 9191-0
Fax + 49 (0) 7944 / 9191-77
Mail: info@hsm-forest.com
www.hsm-forest.com

Technical data 208F 6 Cylinder

Engine:

- IVECO
- NEF 6 Cyl. Common Rail Turbo / TIER3
- power: 175 kW (238 HP)
- max. revolution: 2200 rpm
- max. torque: 1020 Nm at 1500 rpm
- displacement: 6,7 liter

Power train:

- 1-hydrostat-engine
- NAF 2 speed transfer gearbox
- optional: HSM High Speed Drive (serial 71) speed at 1st gear 0-16 km/h

Brake:

- brake with 2-circles, oil-cooled multiple-disc power-brake
- spring accumulator - parking brake

Steering:

- articulated frame steering with 2 cylinders
- steering angle 45°

Hydraulic system:

- load sensing
- variable pump (working pump):

flow rate:	304 l/min at 1600 rpm
pressure:	up to max. 350 bar
- fixed displacement pump:

flow rate:	17,6 l/min at 1600 rpm
pressure:	120 bar
- hydraulic oil: saturated, synthetic ester Panolin HLP SYNTH with Kleenoil microfiltration WGK 1 Rexroth
- valve block: HSM ECOMmand with graphic-colour-display, menu navigation via scroll wheel, diagnosis-tool and error-indication, 5 operator programs

Cabin:

- raisable to side on parallel linkages
- ROPS, FOPS, OPS tested
- rotary seat with pedals in front and rear
- wiper in front and rear, optional on the side
- air cushioned seat
- hot-water heating
- air conditioning

Electrical system / Instruments:

- HSM Ecomand colour-display
- 5 operator programs + factory setting
- diagnosis-tool and error-indication
- graphic support at parameter editing
- generator 24 V, 90 A
- 4 service-free dry batteries á 56 Ah

Oscillation lock:

- 2 hydraulic cylinders

Standard equipment:

- 12 LED-working headlight at cabin
- 2 working headlights at crane
- potential transformer
- radio with CD
- fire extinguisher
- first aid kit
- warning triangle
- tool kit
- cooling box

Special equipment:

- front dozer-blade
- tandem axle lift (Bogielift) front
- single-drum winch 7 t / 10 t
- turnable rung
- last rung plugged
- tilttable crane
- quick-change system for rungs
- clambunk
- auxiliary heating
- bogie-tracks
- radio control for winch
- drive by radio
- sun blinds
- 2 LED-working headlights at crane
- other options on request

208F 11 t

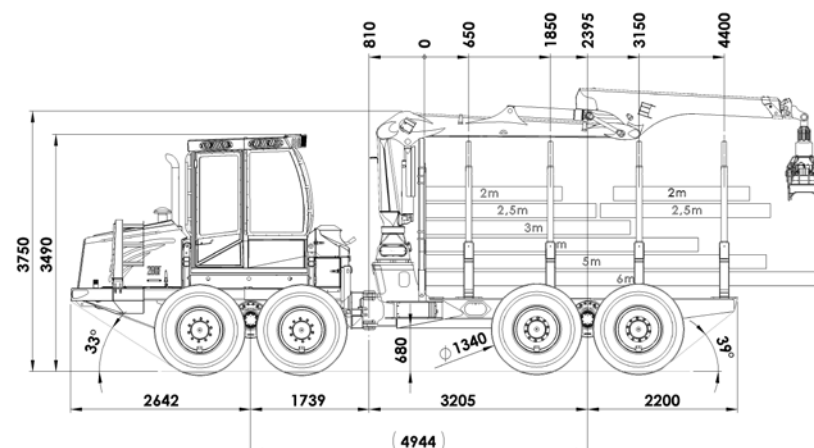

Weight:

- 16000 kg (serial)
- weight distribution: front axle: 60 %
rear axle: 40 %

Tires:

	width:	overall width:	width for tracks:
• serial:	710/45-26,5	2600 mm	2700 mm
• optional:	600/55-26,5	2300 mm	2400 mm
	800/40-26,5	2700 mm	2800 mm
	54x37-25	2900 mm	3000 mm

Axles:

- NAF portal-bogie-axes
- front: switchable differential lock 100 %
- rear: switchable differential lock 100 %

Crane:

- serial: - Epsilon M70 F80

- other cranes behold crane-list

Tank:

- diesel: 190 l
- hydraulic oil: 130 l

Loading area:

- 4 rungs
- length: 4400 mm
- cross section: 4,0 m² / option 4,3 m²
- load capacity: 11 t

208F 12 t

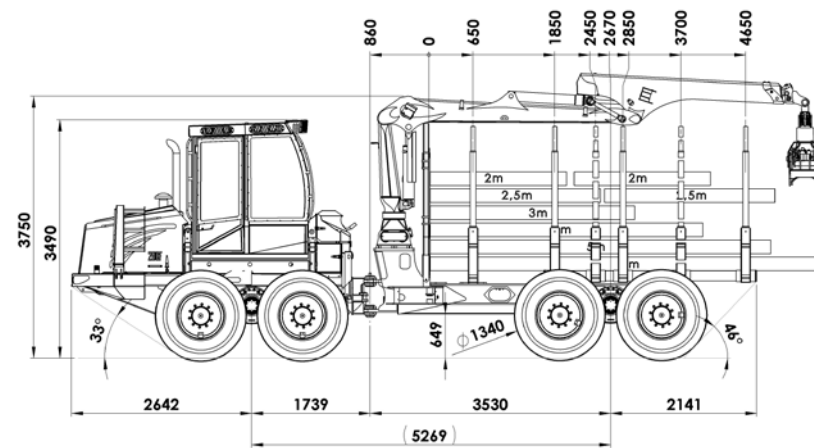

Weight:

- 16500 kg (serial)
- weight distribution: front axle: 60 %
rear axle: 40 %

Tires:

	width:	overall width:	width for tracks:
• serial:	710/45-26,5	2600 mm	2700 mm
• optional:	600/55-26,5	2300 mm	2400 mm
	800/40-26,5	2700 mm	2800 mm
	54x37-25	2900 mm	3000 mm

Axles:

- NAF portal-bogie-axes
- front: switchable differential lock 100 %
- rear: switchable differential lock 100 %

Crane:

- serial: - Epsilon M70 F80

- other cranes behold crane-list

Tank:

- diesel: 190 l
- hydraulic oil: 130 l

Loading area:

- 4 rungs, last rung extensible
- length: 3700 mm - 4650 mm / option 5050 (2x3 m)
- cross section: 4,0 m² / option 4,3 m²
- load capacity: 12 t

208F 14 t

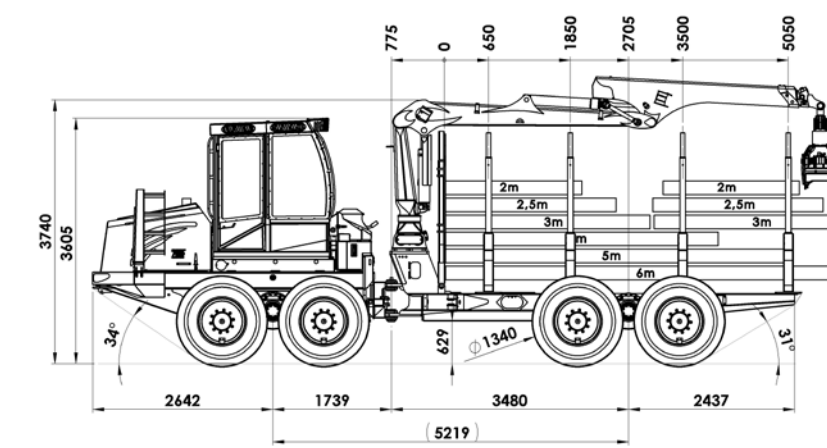

Weight:

- 17500 kg (serial)
- weight distribution: front axle: 60 %
rear axle: 40 %

Tires:

	width:	overall width:	width for tracks:
• serial:	710/45-26,5	2860 mm	2960 mm
• optional:	600/55-26,5	2660 mm	2760 mm
	800/40-26,5	3000 mm	3000 mm

Axles:

- balanced NAF portal-bogie-axes
- front: switchable differential lock 100 %
- rear: switchable differential lock 100 %

Crane:

- serial: - Epsilon M70 F80

- other cranes behold crane-list

Tank:

- diesel: 180 l
- hydraulic oil: 130 l

Loading area:

- 4 rungs
- length: 5050 mm
- cross section: 4,4 m²
- load capacity: 14 t

208F 6WD

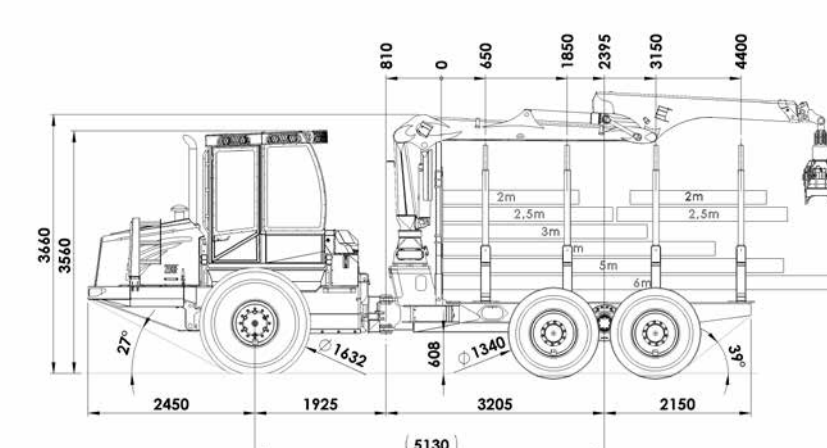

Weight:

- 16000 kg (serial)
- weight distribution: front axle: 60 %
rear axle: 40 %

Tires:

	size front:	size rear:
• serial:	23.1-26	710/50-26,5
• optional:	28L-26	600/55-26,5
	24,5x32	800/40-26,5
	30,5x32	

Axles:

- NAF planetary axle
- front: switchable differential lock 100 %
- NAF portal-bogie-axes
- rear: switchable differential lock 100 %

Crane:

- serial: - Epsilon M70 F80

- other cranes behold crane-list

Tank:

- diesel: 260 l
- hydraulic oil: 140 l

Loading area:

- 4 rungs
- length: 4400 mm
- cross section: 4,0 m² / option 4,3 m²
- load capacity: 10 t